

(No Model.)

B. BLAKE.
RECOIL CHECK FOR FIREARMS.

No. 524,458.

Patented Aug. 14, 1894.

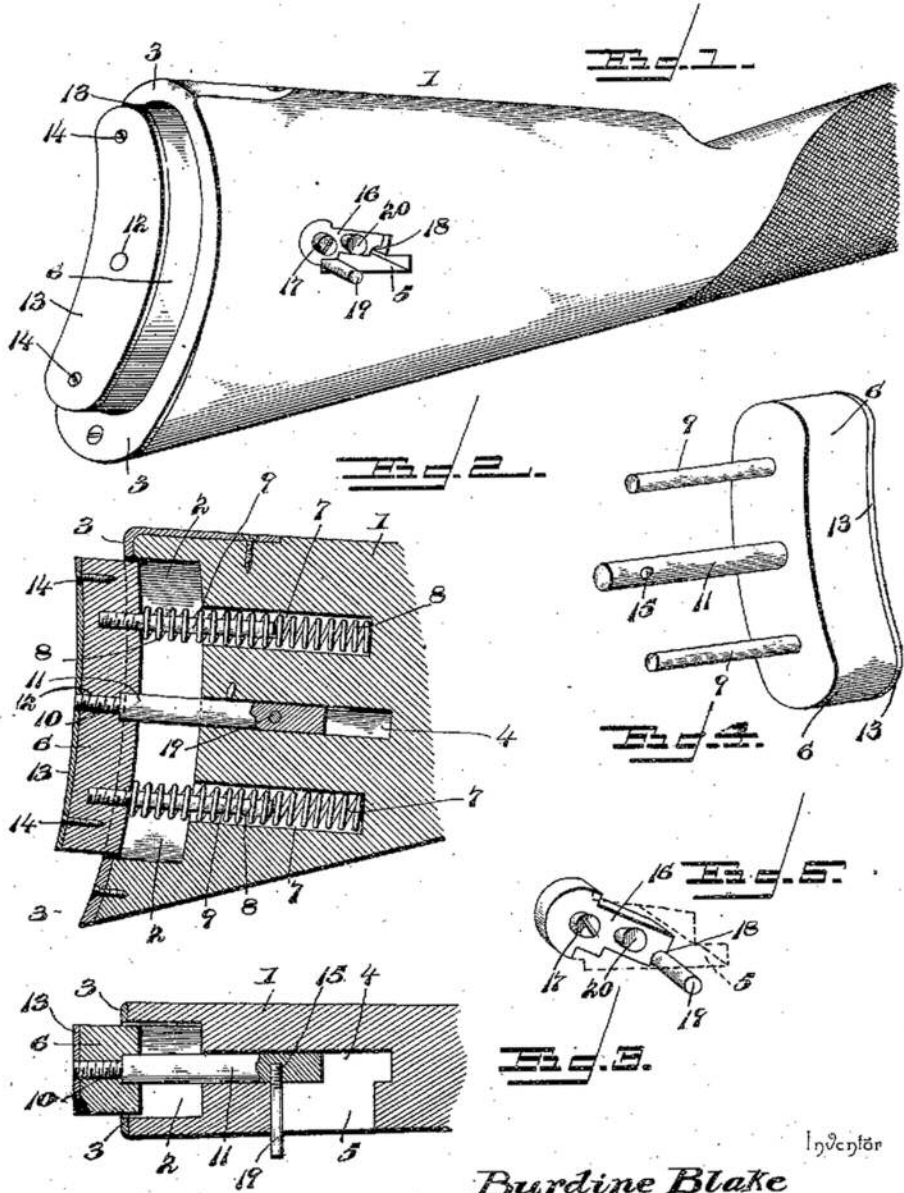

Inventor

Burdine Blake

Witnesses
E. N. Stewart
J. R. [unclear]

By [unclear] Attorneys.

Cashow & Co.

UNITED STATES PATENT OFFICE.

BURDINE BLAKE, OF LONDON, OHIO.

RECOIL-CHECK FOR FIREARMS.

SPECIFICATION forming part of Letters Patent No. 524,458, dated August 14, 1894.

Application filed March 29, 1894. Serial No. 505,590. (No model.)

To all whom it may concern:

Be it known that I, BURDINE BLAKE, a citizen of the United States, residing at London, in the county of Madison and State of Ohio, have invented a new and useful Gun-Stock, of which the following is a specification.

My invention relates to an improvement in that class of gun stocks which are constructed with a portion adapted to engage the operator's shoulder and having a spring co-operating therewith, whereby the shock of the gun's recoil is lost in the elasticity of the spring; and it has for its principal object the production of such a device, and one wherein the shoulder-engaging portion will be capable of being locked flush with the general surface of the gun, thus dispensing with the inconvenience which would otherwise attend it when such portion is not being used.

In the accompanying drawings: Figure 1 represents a perspective view of a gun stock supplied with my improvements; Fig. 2, a vertical longitudinal section thereof; Fig. 3, a horizontal longitudinal section of the same; Fig. 4, a perspective view of the sliding block removed from the gun stock; Fig. 5, a detail perspective, showing the means for locking said block:

The reference numeral 1 indicates the gun stock, which is formed with the cavity 2 in its rear end. This cavity is nearly as large as the thickness of the stock, and is bounded by the brass casting 3, which is rigidly secured to the end of the stock and serves to protect the same. Communicating with the cavity 2, and extending longitudinally with the stock, is the passage 4, and this in turn communicates with the longitudinally-elongated opening 5, extending at right angles thereto and opening on the right-hand side of the stock.

6 indicates the block for engaging the operator's shoulder, and this is of such a size that it will fit snugly within the cavity 2, and fill the entire lateral extent thereof, though enough space is left forward of the block to permit its merging completely into the cavity. Formed in the forward side of the cavity 2, and on opposite sides of the passage 4, are the openings 7, which extend longitudinally into the gun stock and are each provided with the spiral springs 8, which fit into them and project rearwardly from their ends

for a distance about equal to the depth of the cavity.

Rigidly secured to the block 6, directly opposite the openings 7, are the studs or arms 9, which are two in number and adapted to project one into each of the openings 7, so that the rear end of the springs 8 will bear against the front and inner face of the block, and so that the block will be allowed to move into the cavity against the tendency of the springs. To allow this movement it will be necessary to make the openings 7 long enough to receive the whole of the arms 9, and this will be clearly seen in the drawings. Formed in the center of the block 6, and extending longitudinally therein, is the passage 10, in which the rear end of the arm 11 is arranged, and said end is adapted to pass a short distance beyond the block and to screw into the opening 12 of the facing plate 13. The facing plate 13 is shaped in conformity with the rear face of the block 6, and is firmly and rigidly secured thereto by means of the screws 14, which pass through it and into the block. From the block 6 the arm 9 extends forwardly and into the passage 4, and terminates directly opposite the opening 5, where it is provided with the internally-threaded opening 15, in alignment with the opening 5, or transversely with the gun stock.

Screwed into the opening 15, and projecting laterally through the opening 5, to a point just beyond the side of the stock, is the pin 19. The opening 5 is longitudinally elongated and has the swinging catch 16, pivoted alongside it, and at the rear end thereof. This catch consists of a metallic bar pivotally secured in a countersunk recess by means of the spindle 17, and capable of swinging vertically, so as to lie over the opening 5. Formed at the end of the latch 16 is the notch 18, which is adapted to engage the pin 19, and to hold it incapable of rearward movement.

20 indicates a button or stud, which is affixed to the catch 16, and by which the catch may be swung to lie in its recess or over the opening 5, and consequently in and out of engagement with the pin 19.

Thus it will be seen that by means of the arms 9 the movements of the block 6 are limited to the extent of the opening or slot 5, and that by pushing the arm, and hence the

pin 19, forwardly and swinging the catch into engagement with the pin, the block may be held in the cavity 2, and with its plate 13 flush with the facing 3. This will make the gun stock as regular as ordinarily, and when it is to be fired the catch 16 may be disengaged from the pin 19, and the springs 8 allowed to force the block out and ready to engage the operator's shoulder.

10 Having described my invention, what I claim is—

1. The combination of a gun stock, a block mounted on the rear end thereof and having a longitudinal movement on the stock, a spring for giving the block a normal tendency outward, an arm having a stud thereon and rigidly secured to the block, said arm projecting inwardly from the block, and a catch capable of being moved to engage or disengage the stud on the arm, whereby the block may be held pressed inwardly and against the tendency of its spring, substantially as described.

2. The combination of a gun stock, a block mounted on the rear end thereof and having a longitudinal movement thereon, a spring for giving the block a tendency outward, an arm rigidly secured to the block and projecting in-

wardly therefrom and into the stock, said arm having a stud thereon, the stud being arranged to extend through a longitudinally-elongated slot in the stock and to project outside thereof, and a catch secured to the stock and capable of being moved to engage or disengage the stud on the arm, whereby the arm, and consequently the connected block, may be held incapable of movement independent of the stock, substantially as described.

3. The combination of a gun-stock having a cavity in the rear end thereof, a block slidably mounted in said cavity, a spring for giving the block a normal tendency rearwardly, and a catch on the gun-stock and capable of connection and disconnection with the block, whereby the block may be held within the cavity or allowed to move out of the same, substantially as described.

In testimony that I claim the foregoing as my own I have hereunto affixed my signature in the presence of two witnesses.

BURDINE BLAKE.

Witnesses:

CARY JONES,
E. P. FISHER.